

400 Series 404F-22T Industrial

EU Stage IIIB / EPA Tier 4 Final / MLIT Step 4
36.4-45.5 kW / 48.8-61 hp

The new Perkins 400F range of engines is an evolution of the highly successful Perkins 400D range and has been designed to meet the latest set of emissions in Europe, North America and Japan.

For our customers these compact, 4 cylinder engines offer a simple, cost effective solution for the upgrade to the next level of emissions in 2013.

The 404F-22T is a turbocharged, 2.2 litre, 4 cylinder engine, capable of producing up to 45.5 kW (61 hp). This small, efficient package delivers excellent torque at low speed, reduced operating costs and extremely low noise and harshness.

The core engine has 95% build and component commonality with the 400D range which means our customers can benefit from minimum machine change and development costs.

An extensive range of options is offered that make the 400 Series the complete solution for compact power needs.

Perkins have developed a reputation for designing and building reliable and durable engines suitable for the most demanding off-highway applications.

Engine data

Number of cylinders	4 vertical in-line
Bore and stroke	84 mm x 100 mm (3.3 in x 3.9 in)
Displacement	2.2 litres (135 cubic in)
Aspiration	Turbocharged
Cycle	4 stroke
Combustion system	Indirect injection
Compression ratio	23.3:1
Rotation.....	Anti-clockwise, viewed on flywheel
Cooling system	Liquid
Total lub system capacity (engine only)	10.6 litres (2.8 US gal)
Total coolant capacity (engine only).....	3.6 litres (0.9 US gal)
Dimensions	
Length Including fan.....	727 mm (28.6 in)
Width.....	635 mm (25.0 in)
Height.....	772 mm (30.4 in)
Dry weight	228 kg (503 lbs)

*includes flywheel housing, flywheel, burner, DPF and air pump

Final weight and dimensions will depend on completed specification

Emissions

Designed to meet 2013 EU Stage IIIB (Europe), EPA Tier 4 (US) and MLIT Step 4 (Japan) emissions requirements.

Reliable, Quiet, and Durable Power

World-class manufacturing capability and processes coupled with proven core engine designs assure reliability, quiet operation, and many hours of productive life.

Innovative Design

- A world engine that supports all your global legislation needs
- A simple, cost effective solution to meet highest regulated emissions.
- Aftertreatment flexibility for mounting location.
- Electronic control for improved transient response and reduced fuel consumption.

Low Cost of Ownership

- 50% reduced oil consumption
- Easy maintenance and serviceability
- Fuel efficient
- Low maintenance aftertreatment system
- Automatic, transparent aftertreatment management
- 500 hour service intervals and 2 year warranty as standard

Local support, global coverage

- Perkins recognise that the customer relationship is important to machine manufacturers and we can offer a range of flexible solutions to help provide appropriate support, either to the OEM's network or directly to the machine customer.
- With highly trained Perkins distributors in thousands of communities in over 180 countries, you are never far away from expert product knowledge, genuine parts and a range of advanced diagnostic technology for keeping your engine in peak condition

Warranties and Service Contracts

We provide one-year warranties for constant speed engines and two-year warranties for variable speed models, as standard. These are supported by multilevel Extended Service Contracts that can be bought additionally



400 Series 404F-22T Industrial

EU Stage IIIB / EPA Tier 4 Final / MLIT Step 4
36.4-45.5 kW / 48.8-61 hp

Engine specification

Core engine

- Multiple engine rating options
- Cast iron engine block
- SAE A PTO drive
- Flywheel and flywheel housing options
- Adapter plate
- Glow plug starting aid
- Cast iron exhaust manifold options
- Induction manifold options
- Engine mounting

Fuel system

- Simple, robust indirect injection fuel pump
- Spin on fuel filter
- Simple pintle nozzle injectors

Electrics

- Starter motor 12 volts
- Alternator 12 volts, 85 amp

Air system

- Turbocharger
- Standard air cleaner

Cooling system

- Belt driven coolant pump
- Cooling fan options
- Fan drive options
- Coolant temperature switch

Lubrication system

- Oil sump options for various applications
- Spin on oil filter options
- Oil pressure switch

Control system

- Electronic control module
- Flexible and configurable software features and well supported SAE J1939 CAN bus enables highly integrated machines
- Wiring harness
- All connectors and wiring harness are waterproof and designed to withstand harsh off-highway environments
- Robust reliable sensors

Emissions control system

- High efficiency DOC / DPF
- Air pump

Options group

- An extensive range of selectable options are available to enable you to prepare a specification precisely matched to your needs.

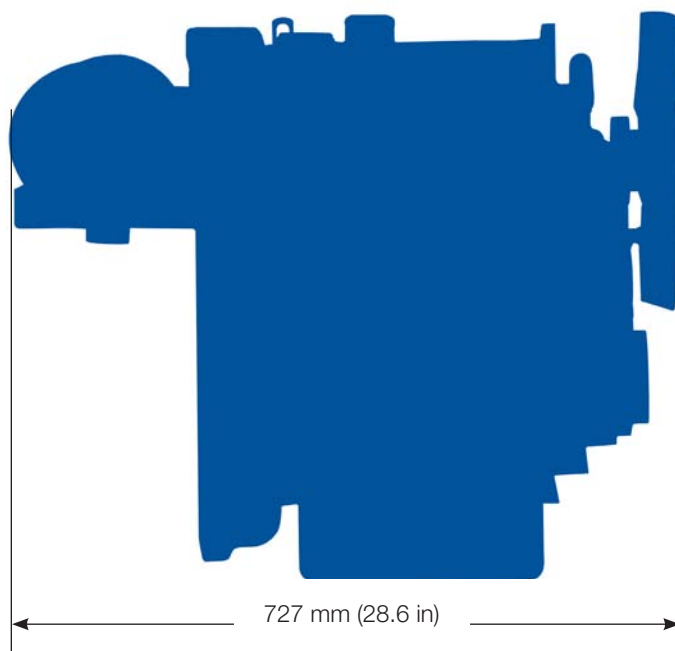
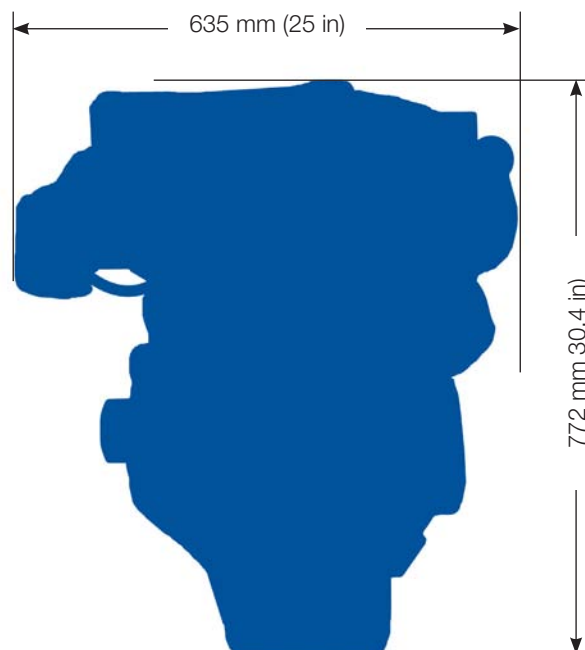

Final dimensions will depend on completed specification

Photographs are for illustrative purposes only and may not reflect final specification.

All information in this document is substantially correct at time of printing and may be altered subsequently.
Publication No. PN2008/09/12 Produced in England ©2012 Perkins Engines Company Limited

400 Series 404F-22T Industrial

EU Stage IIIB / EPA Tier 4 Final / MLIT Step 4
36.4-45.5 kW / 48.8-61 hp

Performance data

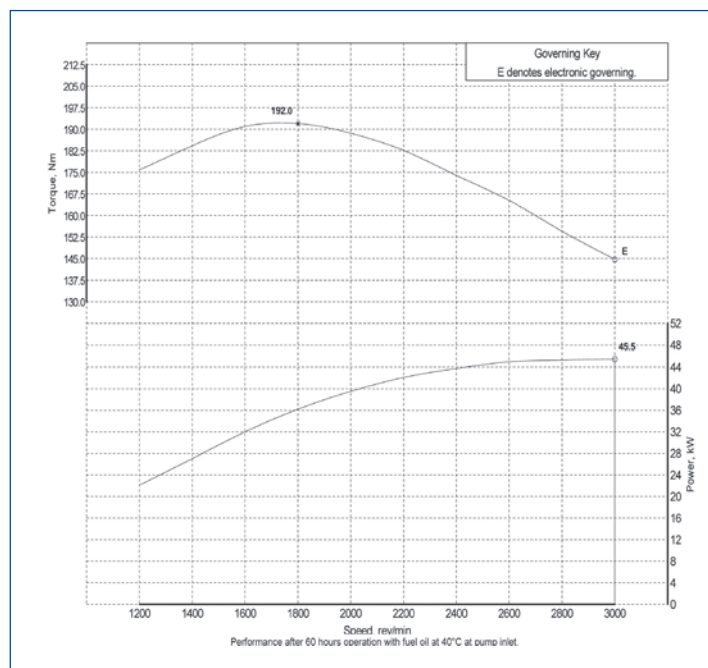

'C' Rating		Speed (rev/min)	Torque	
kW	bhp		Nm	lbf-ft
36.4	48.8	2600	185*	136.4*
36.4	48.8	2800	154	113.6
40.0	53.6	2600	192	141.6
41.5	55.7	2600	185*	136.4*
44.7	60.0	2800	192	141.6
45.5	61.0	3000	192	141.6

* balanced

Rating Standard ISO 14396:2002

Unless otherwise specified, all stated data is for maximum rated speed and 100% load.

Rating definitions and conditions

IND-C (Intermittent) is the horsepower and speed capability of the engine where maximum power and/or speed are cyclic (time at full load not to exceed 50%).

Additional ratings are available for specific customer requirements. Consult your Perkins distributor.

Rating Conditions for Diesel Engines - up to 7.1 litres are based on ISO/TR14396, inlet air standard conditions with a total barometric pressure of 100 kPa (29.5 in. Hg), with a vapour pressure of 1 kPa (0.295 in Hg) and 25°C (77°F). Performance is measured using fuel to specification EPA 2D 89.330-96 with a density of 0.845-0.850 kg/L @ 15°C (59°F) and fuel inlet temperature 40°C (104°F).

- Variable Speed: Industrial and IOPU engines: Certified against the requirements of EU Stage IIIB (Directives 97/68/EC, as last amended, and 2004/26/EC, as last amended); and US EPA Tier 4 Final (40 CFR Part 1039).
- Constant Speed Engines for use in Industrial, IOPU and ElectropaK applications: Certified against the requirements of EU Stage IIIA (Directives 97/68/EC, as last amended for mobile applications); and US EPA Tier 4 Final (40 CFR Part 60 for stationary applications and 40 CFR Part 1039 for mobile applications).

Photographs are for illustrative purposes only and may not reflect final specification.

All information in this document is substantially correct at time of printing and may be altered subsequently.
Publication No. PN2008/09/12 Produced in England ©2012 Perkins Engines Company Limited

400 Series 404F-22T Industrial

EU Stage IIIB / EPA Tier 4 Final / MLIT Step 4
36.4-45.5 kW / 48.8-61 hp

Aftertreatment configuration

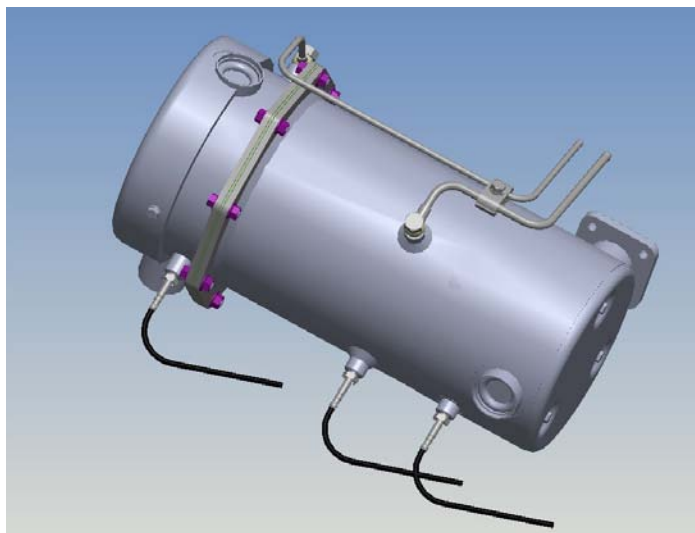

Aftertreatment		
Length	Diameter of Can	Weight
449 mm (17.6 in)	198 mm (7.8 in)	16 kg (35.3 lbs)

Final weight and dimensions will depend on completed specification

Technology

The Diesel Particulate Filter (DPF) technology chosen performs through the whole work cycle of the engine thus allowing it to work efficiently.

Power

Using our advanced research and development techniques, we have perfectly matched the aftertreatment to the engine. The engine performance has then been optimised to give the maximum power and the emissions module is invisible to the operator in most duty cycles.

Mounting

Multiple on or off engine installation options provide OEM with simple and flexible solutions for many applications.

Service

Minimum 3,000 hour DPF ash service intervals..

Aftertreatment

- DOC – Diesel Oxidation Catalyst
- DPF – Diesel Particulate Filter supplied, with a range of inlet and outlet options

Regeneration System

- Non intrusive regeneration strategy maintains machine productivity.
- Highly effective passive regeneration under most operating environments and cycles.
- Automatic, transparent active 'back up' system during light load or adverse operating cycles.

Photographs are for illustrative purposes only and may not reflect final specification.

All information in this document is substantially correct at time of printing and may be altered subsequently.
Publication No. PN2008/09/12 Produced in England
©2012 Perkins Engines Company Limited

Perkins Engines Company Limited

Peterborough PE1 5FQ
United Kingdom
Telephone +44 (0)1733 583000
Fax +44 (0)1733 582240

www.perkins.com



THE HEART OF EVERY GREAT MACHINE