

400 Series 403F-07 Industrial

8.8 kW / 11.8 hp @ 2200 rpm

The latest Perkins® 400F range of industrial engines is an evolution of the highly successful and productive Perkins 400D range and has been developed specifically to meet the latest set of emissions in North America.

For our customers, these compact 3 and 4 cylinder engines offer a simple, cost effective upgrade to the latest stringent EPA legislation.

This 0.7 litre, 3 cylinder engine complements the exciting Perkins 400 Series product line-up, offering customers an ultra-compact, lightweight power unit that maintains all the customer benefits they can experience from other products in the range.

With no change to the core engine or hook up points and a high level of component commonality with 400D range, our customers benefit from minimum machine change and development costs to upgrade to Tier 4 Final and a common machine for export markets.

The comprehensive 400 Series engine family continues to set new standards in the compact engine market. Developed alongside customers to fulfil their needs in the construction, materials handling, agricultural/turf, genset and compressor markets, it is another class-leading diesel range from Perkins.

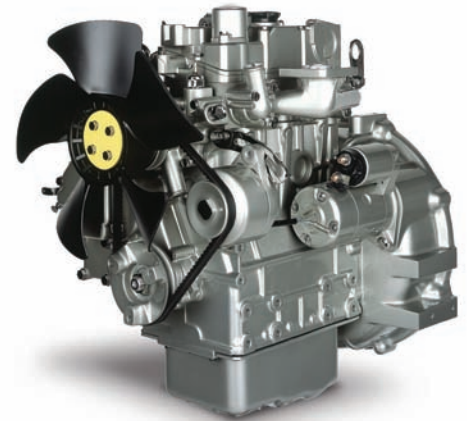

Ultra-compact power

- Up to 9 kW (12 hp) from an engine envelope of 0.09 cubic metres (3.1 cubic ft)
- Easy installation even in the smallest of machines

Clean and quiet

- Noise levels have been kept to a minimum
- Subjective harshness has been carefully controlled making the engine sound even quieter

Durable power

- Product design and process improvements enhance both engine reliability and durability
- The introduction of a simple electronic governor system gives customers the flexibility of electronic machine integration if needed.
- A standard two-year warranty demonstrates our confidence in durability and reliability

Low operating costs

- Approved for operation on biodiesel* concentrations of up to 20%
- Oil and filter changes are 500 hours, dependent on load factor
- Engine durability and reliability, the warranty offering and ease of installation combine to drive down the cost of ownership

Product support

- With highly trained Perkins distributors in thousands of communities in over 180 countries, you are never far away from expert product knowledge, genuine parts and a range of advanced diagnostic technology for keeping your engine in peak condition

Warranties and Service Contracts

We provide one-year warranties for constant speed engines and two-year warranties for variable speed models, as standard. These are supported by multilevel Extended Service Contracts that can be bought additionally

[Discover more](#)

www.perkins.com

www.perkins.com/esc

www.perkins.com/distributor

[To find your local distributor](#)

Performance Data	Gross Intermittent (ISO/TR 14396)	Speed rpm
Power Output (kW)	8.8	2200
Power Output (hp)	11.8	2200
Peak Torque (Nm)	39.9	1800
Peak Torque (lbf.ft)	29.4	1800

*Subject to conformance with ASTM D6751 and EN14214.

Power output for a run in engine after 60 hours

400 Series 403F-07 Industrial

8.8 kW / 11.8 hp @ 2200 rpm

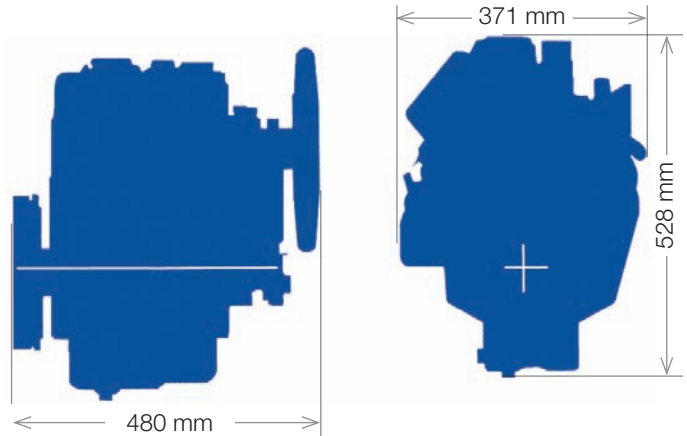

Engine specification

- Cast iron engine block
- Flywheel and flywheel housing
- Fuel injection pump
- Spin on fuel filter
- Glow plug starting aid
- Lub oil sump
- Spin on lub oil filter
- Inlet manifold
- Cast iron exhaust manifold – side outlet
- Closed circuit breather
- Coolant pump belt driven
- Starter motor 12 volt
- Electronic governor
- Alternator 12 volt 40 amp with DC output
- Lub oil pressure switch
- Coolant temperature switch
- Choice of coolant fans
- Cold start capability to -20°C (aided)
- Gradeability 35° continuous

Engine data

Number of cylinders	3 in-line
Bore and stroke.....	67 x 72 mm (2.6 x 2.8 in)
Displacement	0.76 litres (46.5 cubic in)
Aspiration	Naturally aspirated
Cycle.....	4 stroke
Combustion system.....	Indirect injection
Compression ratio	23.5:1
Rotation.....	Clockwise viewed from front
Cooling system.....	Liquid 50/50 antifreeze
Total lubrication capacity	3.05 litres (0.8 US gals)
Total coolant capacity	1.2 litres (0.3 US gals)
Dimensions	
Length	480 mm (18.9 in)
Width.....	371 mm (14.6 in)
Height.....	528 mm (20.8 in)
Dry weight	71 kg (156.5 lb)
Final weight and dimensions will depend on completed specification.	

Option groups

A selection of optional items is available to enable you to prepare a specification precisely matched to your needs.

Emissions statement

Industrial and IOPU Engines: Certified against the requirements of US EPA Tier 4 Final (40 CFR Part 1039). Less than 19 kW EC certification not required.

Constant Speed engines for use in Industrial, IOPU and ElectropaK applications: Certified against the requirements of US EPA Tier 4 Final (40 CFR Part 60 for stationary applications and 40 CFR Part 1039 for mobile applications). Less than 19 kW EC certification not required.

Photographs are for illustrative purposes only and may not reflect final specification.

All information in this document is substantially correct at time of printing and may be altered subsequently.
Publication No.PN3037/09/13 Produced in England ©2013
Perkins Engines Company Limited

Perkins Engines Company Limited

Peterborough PE1 5FQ
United Kingdom
Telephone +44 (0)1733 583000
Fax +44 (0)1733 582240
www.perkins.com



THE HEART OF EVERY GREAT MACHINE